



# UNB HEAD HALL Engineering Commons

University of New Brunswick,  
Fredericton





1

## PROJECT OVERVIEW AND ARCHITECTURAL PROGRAM

**By Greg Murdock, FRAIC, AANB  
Murdock & Boyd Architects**

The Engineering Complex at UNB is comprised of five buildings, all constructed at different times, and physically connected as one. The first building constructed in 1901, was the original Engineering Building, designed in the Romanesque Revival style, followed closely thereafter by the former Gymnasium, converted in 1944 to the Electrical Engineering Building. In 1957, an expansion to the western side of the two original engineering buildings was made. Sir Edmund Head Hall, a five-storey, 13,600 sq.m (140,000 sf) addition was constructed to the north of the previous mentioned buildings. Gillin Hall was added to the west side of Head Hall in 1989 and the Information Technology Centre was added to the south of Gillin Hall along Windsor Street in 2000.

In April of 2017, UNB requested Murdock & Boyd Architects to come up with a design solution for a new prominent Main Entrance to the Head Hall Engineering Complex, one that celebrates the engineering programs that are delivered at this institution. The space is designed to allow for and promote the collaboration and interaction of students and faculty, provide for additional graduate study areas, larger crush space from the Dineen Auditorium and a space to exhibit and visually celebrate all the disciplines of the world renowned UNB Engineering programs and its graduates.

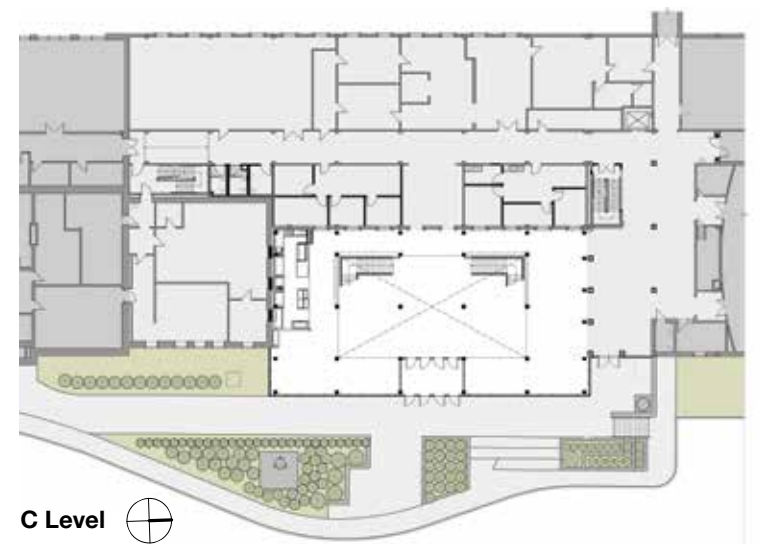

C Level

1. The new glulam framing of the atrium inserted next to the existing building facades.

The new space on the main floor contains the relocated Head Rest Café and associated seating, in addition to open areas for engineering students, project display and student interaction. The second level provides Group Study offices along with open seating areas for informal group study and collaboration. The third level has space for the Student Success Centre and a Design Studio. The basement level accommodates an Undergraduate Computer Lab, a Research Lab and a new Mechanical Room. The floor plate is approximately 465 sq.m (5,000 sf) per floor.

Leaning on the history of our province, one of our many natural resources is the forestry sector. The area on the site where the new Engineering Commons is located contained three trees that unfortunately had to be removed. So, to memorialize those trees and to pay tribute to New Brunswick's strong forestry economy, the design team considered a structural engineered frame and floors constructed of mass timber elements. The glue-laminated (glulam) wood columns and beams and the underside of the cross laminated timber (CLT) floor and roof slabs are exposed to exhibit the warmth, texture and strength of timber. The structural grid of the existing building at 20' was conveniently well suited for a mass timber solution. All of the mechanical engineering systems are exposed to view as well.



D Level

2. The skylight supported on the glulam framing fills much of the atrium with natural light.



2

HVAC ducting, and water and heating piping, are positioned to showcase those engineering systems. In addition, the electrical conduit runs and light fixtures are integrated with the other engineering systems to provide a virtual laboratory of all of these particular engineering elements.

The project was designed using Revit Modelling software. Most consultants have developed their systems using this software and the model contains all of the designed elements and systems for each discipline. As the project moved into the Construction Document phase, the model continued to be developed, up to the time in preparing the 2D construction documents.

Where the addition fills in the current landscaped area between Head Hall and the 1901 Engineering Building, there is one exterior wall facing east. This three-storey exterior wall encompasses a glazed curtain wall system to identify the new main entrance and to provide an aesthetic contrast to the red brick facades of the engineering buildings along Dineen Drive.

A slightly protruding building element framed in UNB red-coloured composite metal panels identifies the new main entrance to the entire complex. The protruding central facade element continues over the top of the addition and permits the use of a large skylight to bring natural light down into the centre structural bays of the new lobby and into the depths of the existing Head Hall spaces. The existing former red brick-clad exterior walls now become the back drop to the beauty of the exposed glulam columns and beams and CLT floor slabs.

## SITE

The new main entrance for the Engineering Complex is now located slightly up the hill, to the south, from the present entrance into Head Hall. The sidewalk coming down Dineen Drive continues onto the new entrance plaza at the new main entrance, incorporating both an accessible level entry and a new stone stair, space for bicycle parking, gardens and casual seating areas. The existing engineering monument has been relocated in an area of prominence near the main entrance.

3. The addition fills a former landscaped area between Head Hall and the 1901 Engineering Building with only one exterior wall facing east toward the street.  
4. HVAC ducting, and water and heating piping are exposed against the CLT floor/ceiling.  
5. A rendering of the finished atrium. The glulam columns and beams, and CLT floor and roof slabs pay tribute to New Brunswick's strong forestry economy.



## NEW ATRIUM LOBBY

The mass timber structural frame and floor members and the existing exterior brick walls are the predominant finishes. The east wall is a glazed curtain wall, using a variety of fritted grey tone glass units, to control glare, yet at the same time allowing quality daylighting. The entrance doors, as part of the curtain wall system, are fully glazed, with exit and accessible hardware.

The two entrance lobby stair elements use steel-framed stringers with porcelain tile treads and landings, with colour contrasting strips at the nosing and tactile warning tiles at each landing, glazed guard railings and stainless-steel handrails. The entrance lobby uses a walk-off mat system to help control the amount of outside moisture being tracked in.

New partitions on all three floors in the atrium space are painted gypsum board and the use of glass panels in selected areas to permit views from and into internal rooms. On Level B, new rooms and spaces have suspended acoustic ceiling systems.

Most new interior doors are solid core wood, stain grade veneer or a wood grain plastic laminate finish. Door and borrowed light frames are pressed steel, painted. Spaces requiring 1 HR fire separation, will utilize firelight glazing in the pressed steel frames.

Architectural casework is plastic laminate covered particle board cased bodies, doors/drawers and shelving. Countertops are pre-formed plastic laminate.

The roof of the new Atrium addition is constructed at a level below the adjacent existing roof levels to avoid adding snow load to those roof areas. A two-ply self-adhered modified bitumen roof membrane system is used. Where the wood roof deck is constructed flat, tapered insulation is used to create positive drainage to the roof drains. A sloped aluminum framed skylight is constructed on a 600mm (24 in.) high curb, centred over the interior Atrium opening.

The double-glazed 25mm (1 in.) thick insulated glass units have a grey tint and are low E argon filled. The exterior glazing consists of 11.5mm (0.45 in.) heat strengthened tempered glass and the interior glazing of 11.5mm laminated glass. Prefinished metal flashings are used to terminate roofing to adjacent walls and parapets.

The roof canopy over the main entrance area CLT panel structurally connects to the building frame. The underside is exposed CLT with clear stain protection, and a two-ply modified bitumen roof membrane using tapered insulation to create slopes to drains.



The glazed railing system consists of 13mm (0.5 in.) laminated glass secured to the floor structure using stand-off securement fasteners, with handrails secured to glass. The floors are polished concrete on Level C and carpet tile over concrete substrate on Levels D and E, and the ceilings are exposed CLT floor panels.

The mechanical and electrical systems that are exposed to view in the atrium space are organized and finished in a manner to complement the space. Efforts were made to locate services out of the main atrium/skylight area but, where exposed, they are located in a uniform and coordinated alignment: sprinkler lines and electrical conduit are painted in various primary colours for identification, heating risers have colour-coded pvc jackets, and storm water drain lines have white pvc jackets.

## STRUCTURAL

**Structural text by Ryan DeMerchant, PEng.  
Eastern Designers & Company Limited**

The project consists of a four-storey addition (three storeys above ground and a basement) and renovations within the existing building.

The foundations are conventional reinforced cast-in-place concrete and for the most part bear directly on a glacial till stratum. The basement (B level) is formed by reinforced concrete retaining walls and a slab on grade. A portion of the existing building adjacent to the addition has a two-storey basement, and, thus, to avoid inducing lateral pressure on the existing basement walls, the foundations in that vicinity are supported on a series of concrete-filled steel pipe piles.

The ground floor level (C level) is constructed of a formed reinforced concrete flat slab supported by the basement walls and a series of concrete columns.

The upper two floors (D + E Levels) and the roof are constructed of cross-laminated timber (CLT) panels supported on glued-laminated timber beams and columns. The CLT floor panels are 245mm (9.6 in.) thick and the roof panels are 197mm (7.75 in.) thick, both having a maximum span of 6.0m (20 ft.). Attenuation of sound is provided using 25mm of rigid insulation and a 50mm (2 in.) thick concrete topping slab on the CLT floor panels.

6. Detail of the beam-to-column framing with a CLT floor/ceiling slab. In some applications the steel connector on the underside of the beam at the column is covered with wood blocking for a uniform finish and for fire protection of the connector.  
7. The structural grid of the existing building at 20 ft. was well suited for a mass timber solution.

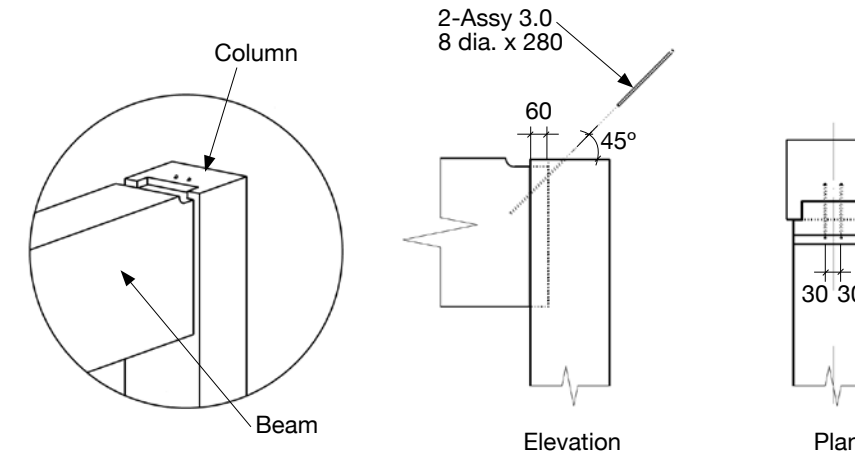
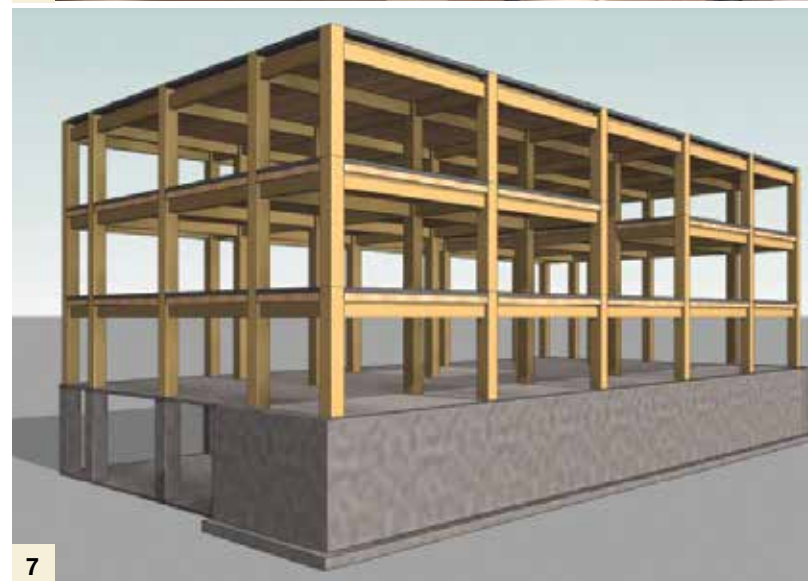

**Glulam beam to column connection**

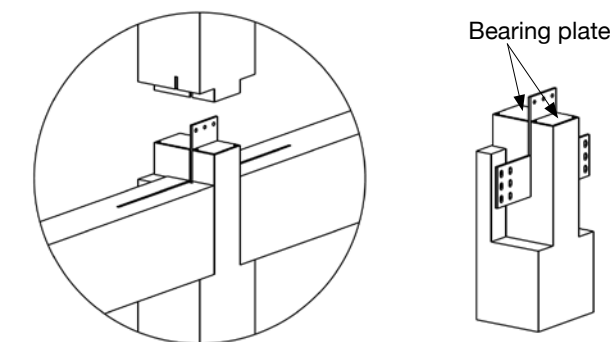

**Typical hole in column bearing plate**

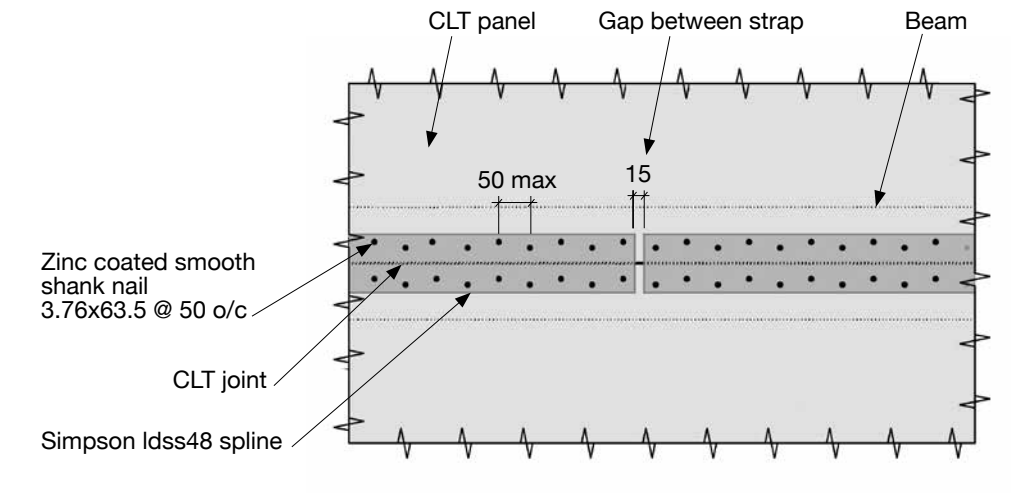

**Plan - CLT to CLT joint with spline**

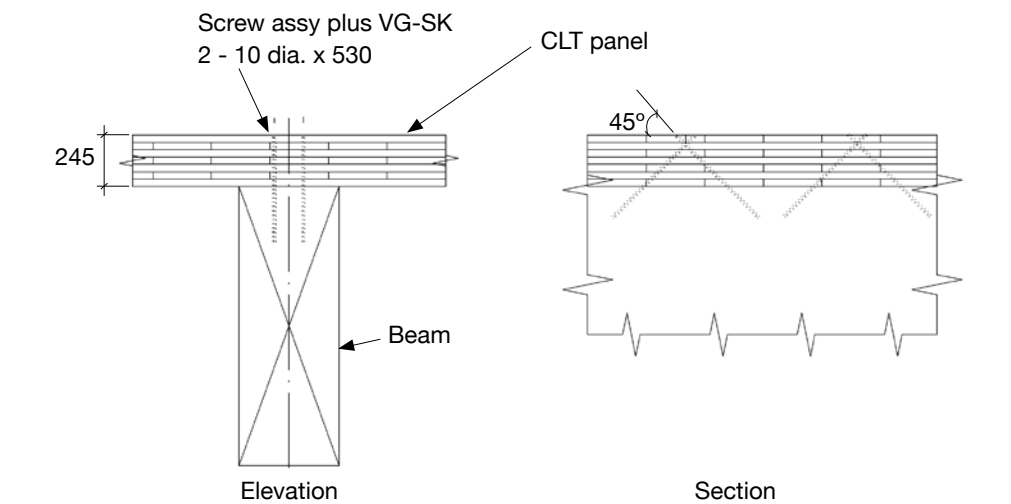

**Screwing pattern CLT panel to beam**

Drawings courtesy of Nordic Structures. Measurements in millimetres.

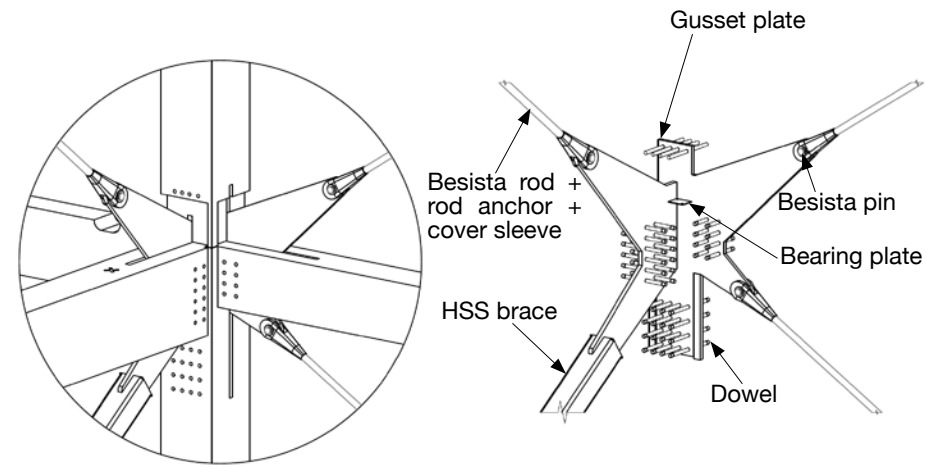

Steel gusset plate with tension rod connector

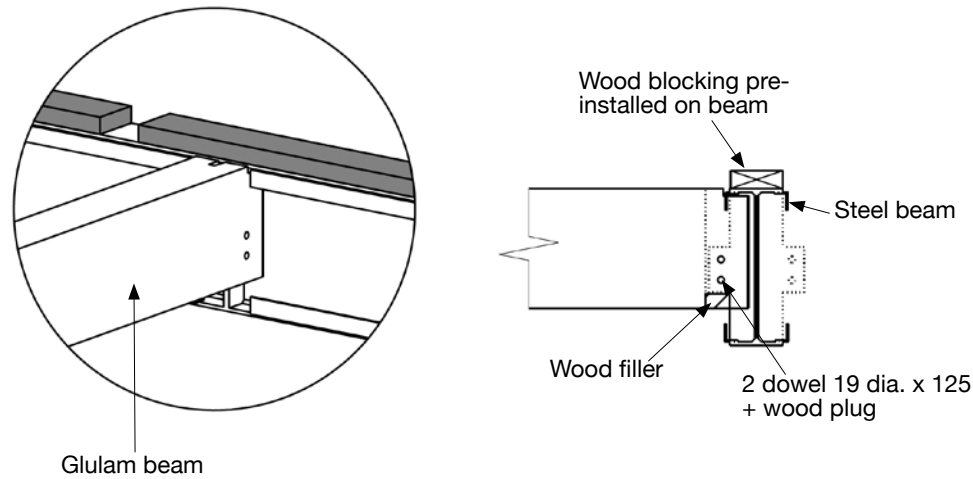

Glulam to steel I-beam connection

Elevation view

Drawings courtesy of Nordic Structures. Measurements in millimetres.

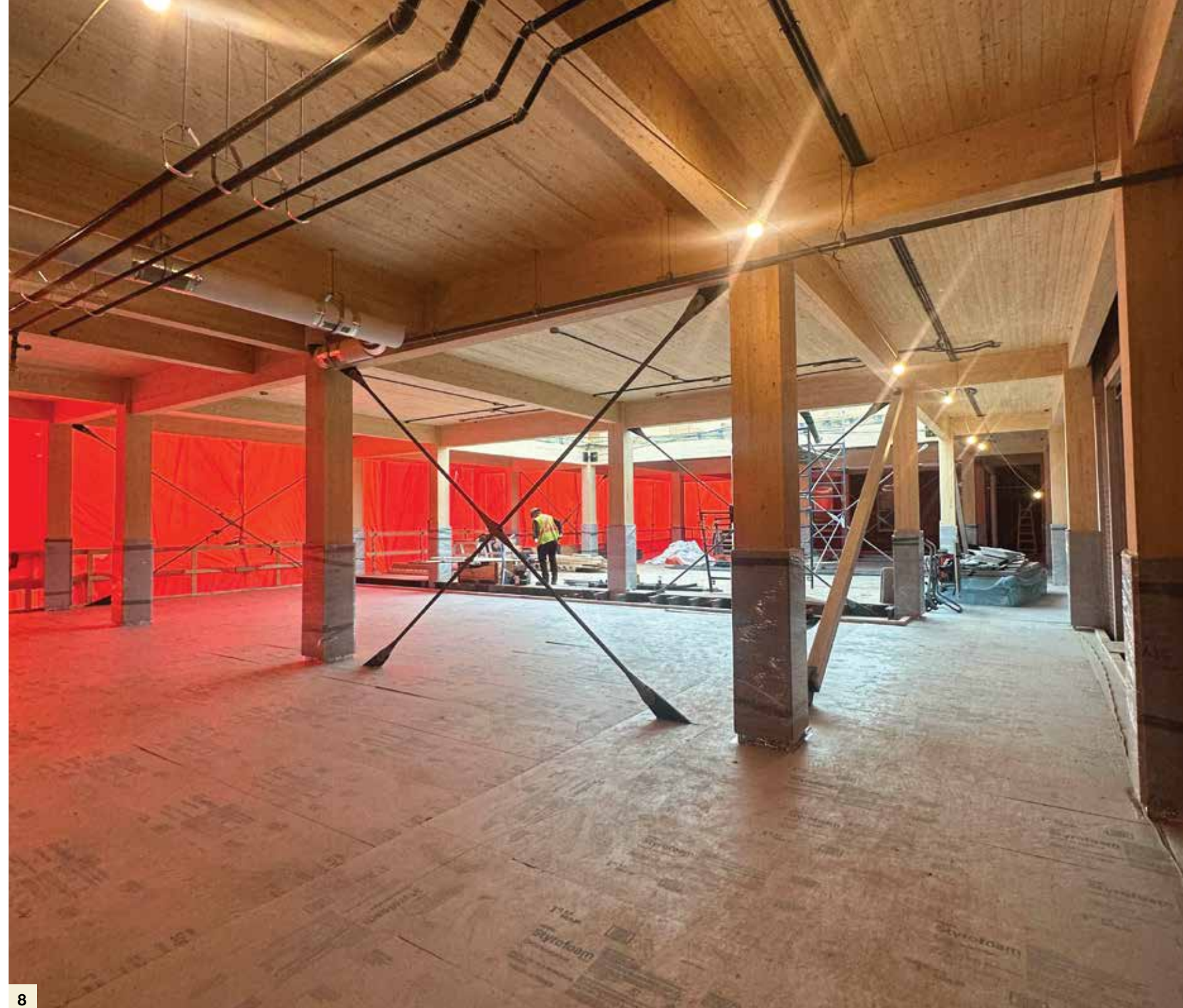

The vertical bracing consists of a combination of a proprietary steel rod system and steel hollow structural sections. The CLT panels are interconnected with light gauge steel plates and fasteners to form the diaphragms.

The glued-laminated timber supplier/fabricator was responsible for design of the connections. The supplier/fabricator opted to replace four glued-laminated timber beams with steel beams that received spray applied fireproofing and a timber encapsulation. The supplier/fabricator opted for this substitution due to the complications that they encountered with ensuring adequate strength and fire resistance rating of the connections of these members.

## EXISTING AREA RENOVATIONS

The adjacent areas to the new Atrium Lobby that are scheduled for renovations are constructed and finished using materials consistent with the existing palette.

Partitions are mainly metal stud framing with painted gypsum board walls. Some select wall areas required the use of painted masonry concrete block to maintain the shear resistance of the existing structure.

Doors are mostly plastic laminate-clad wood doors and painted pressed steel door frames. Borrowed light vision panels are painted pressed steel frames and 6mm (0.25 in.) clear glass panels. New fire-rated doors in existing corridors, located in coordination with sprinkler protection zones, are on hold-open devices.

Ceilings are suspended acoustic panels with lay-in LED light fixtures, and most floors are 300 x 300mm (12in. x 12in.) vinyl composition tiles, with rubber base. Casework is plastic laminate-clad particle board case bodies, doors/drawers, and shelving. Countertops are pre-formed plastic laminate.

A fire protection sprinkler system is installed in other areas, not necessarily being renovated for architectural reasons. This involves the removal of existing acoustic ceiling panels and associated grid to permit the sprinkler piping to be installed, and the reinstatement of the former ceiling system. Some, but not all, of the existing ceiling systems require replacement due to their current condition.

8. Steel tensions rods, which connect to the timber elements with steel gusset plates, provide lateral stability where required.

## BUILDING CODE REVIEW

RJ Bartlett Engineering Ltd (RJBEL) had been retained by Murdock & Boyd Architects (MBA) to develop an alternative solution to permit the use of mass timber structural members in the above grade floors of the proposed addition which is prescriptively required by the 2015 National Building Code of Canada (NBCC) to be of noncombustible construction.

This alternative solution approach involving mass timber structural elements in a building required to be of noncombustible construction, follows all other requirements for a non-combustible building as identified under NBC Subsection 3.1.5. The focus of the alternative solution is then clearly defined by the applicable intent statements of the areas proposed to deviate from the acceptable solutions. This alternative solution thus addresses the following aspects of the building:

- The use of mass timber construction in a building required to be of noncombustible construction, and
- The flame-spread and smoke development properties of the proposed wood products as it relates to interior finish requirements.

Additional topics addressed in this alternative solution include:

- The phasing of sprinkler protection in areas of the building not yet equipped with sprinkler protection,
- Effectiveness of sprinkler protection in a high ceiling area, and
- A review of the applicable requirements for special protection measures along the periphery of the floor openings within the atrium (i.e. draft stops and close-spaced sprinklers).

The applicable major occupancy classification for the building is Group A, Division 2 (Assembly, A-2) with subsidiary Group D (Business and Personal Services). Each floor has a combination of student and faculty offices, classrooms, lounges, and workshop spaces.



9. The early framing stage showing the proximity of the existing buildings.  
10. A rendering of the finished atrium from the same perspective as photo 9.

9

The facility also includes some subsidiary Group F, Divisions 2 and 3 (Medium and Low-Hazard, Industrial) occupancies throughout such as lab spaces, mechanical/electrical rooms, storage rooms, and chemical storage.

The Alternative Solution proved that the characteristics of the mass timber structural elements were capable of maintaining their structural integrity for at least 1 hour, not increase the likelihood of fire growth and spread, and not result in untenable conditions occurring in less time compared to construction materials permitted by the acceptable solutions.

## LESSONS LEARNED

Selection and engagement of a mass timber manufacturer for design assist, as early in the design process as possible, is extremely important. This would permit effective, coordinated and efficient design time by the architect, structural engineer, code consultant and manufacturer. It would also permit discussion and resolution of a number of manufacturers standard details, as these can vary between manufacturers.



10



Project leadership, funding & delivery by



Supported & funded by



## PROJECT TEAM

**ARCHITECT:** Murdock & Boyd Architects

**STRUCTURAL ENGINEER:** Eastern Designers & Company Limited

**MASS TIMBER SUPPLIER:** Nordic Structures

**CONTRACTOR:** EllisDon Corporation

**PHOTOS AND RENDERINGS:** Murdock & Boyd Architects



WoodWorks Atlantic  
(902) 667-3889  
Info@atlanticwoodworks.ca  
www.atlanticwoodworks.ca